

REVISIONS		
ISS	ZONE	DESCRIPTION\PER REQUEST\DATE
A3	ALL	更新圖框
V	OPEN	對客戶公開圖紙
	OPEN	對供應商公開圖紙
	CLOSED	僅限廠內使用

台灣日昇電子股份有限公司
ISSUE APPROVED
 發行核可
本文件與簽核紙本正本相符

- Technique requests(技術要求):
1. Insert force(插入力):<45N (4.5KG)
 2. Withdrawal force(拔出力):<55N (5.5KG)
 3. Locking force(鎖定力):>80N (8.1KG)

- 管控方式: 採用 $\phi 6 \pm 0.02$ 公頭檢測項目:
1. 手動插拔順暢,全檢
 2. 鎖定时吊重8.1kg砝碼不落下,全檢
 3. 以特殊抽樣標準S3進行測試並記錄數值

測試方法:
 插入力測試方法: 公頭插入時,不推動紅色推杆
 拔出力測試方法: 公頭拔出時,須向後推動紅色推杆
 鎖定力測試方法: 公頭拔出時,不推動紅色推杆
 測試三力時,使用的是 $\phi 6 \pm 0.02$ 公頭

13	尾套(BOOT)	PVC	黑色(BLACK)	1	
12	T型圈(T-RING)	POM	白色(WHITE)	1	
11	螺套(CAP)	PA	黑色(BLACK)	1	
10	S端子(S-TERMINAL)	H62	鍍錫(TIN)	1	
9	鋅殼 (DIE-CAST SHELL)	ZZnAL4-1	鍍鎳(NICKEL)	1	
8	R端子(R-TERMINAL)	H62	鍍錫(TIN)	1	
7	T端子(T-TERMINAL)	PHOSPHOR BRONZE	鍍錫(TIN)	1	
6	螺絲(SCREW) M2.5X0.45	Q235	鍍鎳(NICKEL)	1	
5	塞塊(INSERT)	SPONGE	黑色(BLACK)	1	
4	檔粒(STOPPER)	PA	紅色(RED)	1	
3	彈簧(SPRING)	65Mn	鍍鎳(NICKEL)	1	
2	推杆(PUSH BUTTON)	ABS	紅色(RED)	1	
1	基座(PLASTIC BASE)	PA	黑色(BLACK)	1	
NO.	DESCRIPTION	MATERIAL	FINISH	Q'TY	DRAWING NO.

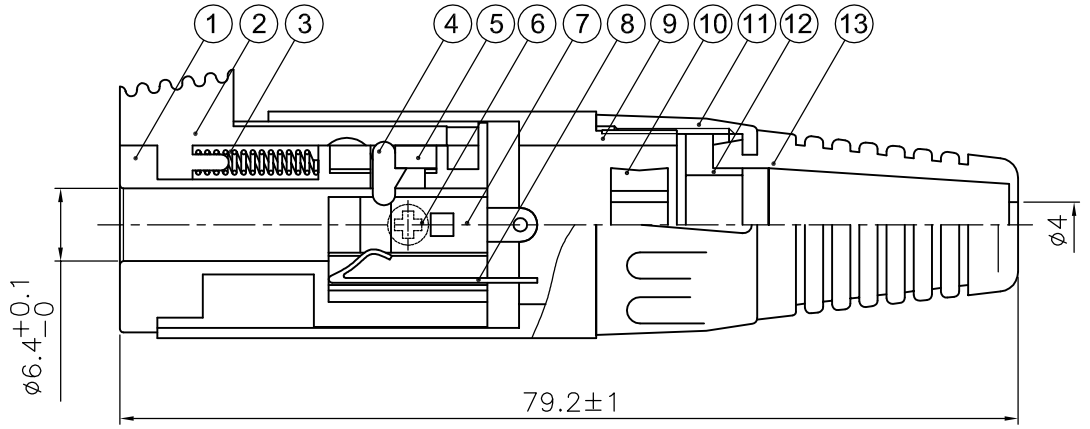
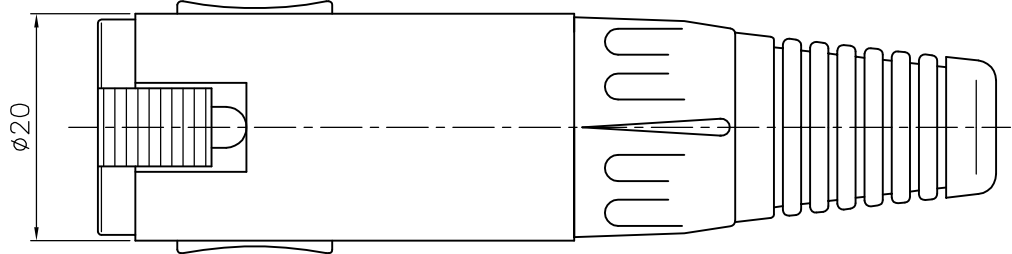

DIMENSIONS ARE IN MILLIMETERS		APPROVED <i>黃碧珊</i> DATE 2020-12-04
UNLESS OTHERWISE SPECIFIED TOLERANCES		CHECKED DATE
ANGLES = $\pm 5^\circ$		DRAWN 吳碧珊 DATE 2018-05-17
UP TO 6 = ± 0.2		
6-40 = ± 0.4		
40-120 = ± 0.6		
120-315 = ± 1		
ABOVE 315 = ± 1.6		FILE NO. D:\CAD\SI\5110010040_SJ246L_CA001A3
THIRD_ANGLE	$\oplus \ominus$	ERP LINK: 5110010040
SCALE	1.5/1	

	日昇電子股份有限公司 SUN RISE EXACT INDUSTRIAL CO.	TITLE	
	6.3mm INLINE LOCKING MONO & STEREO WITH CLAMP CABLE HOLDER		
PART NO.	SJ246L	REV.	A3