

REVISIONS		
ISS	ZONE	DESCRIPTION\PER REQUEST\DATE
A4	ALL	多個品名整合表格,視圖調整位子,多處尺寸修正 ▲
V	OPEN	對客戶公開圖紙
	OPEN	對供應商公開圖紙
	CLOSED	僅限廠內使用

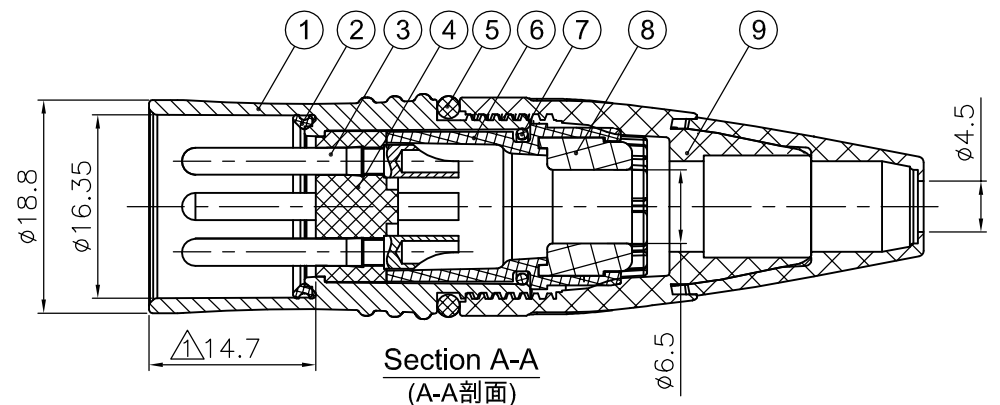
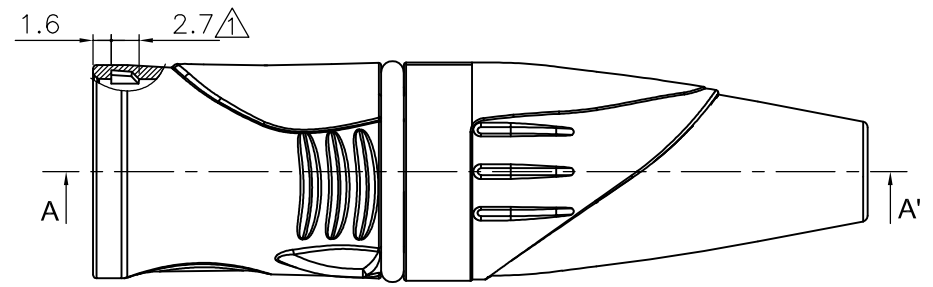
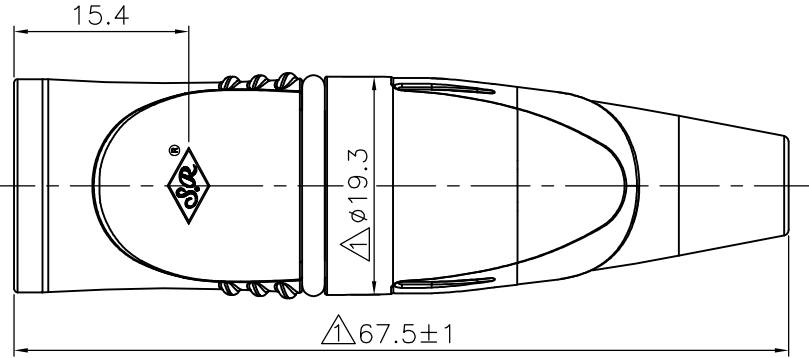
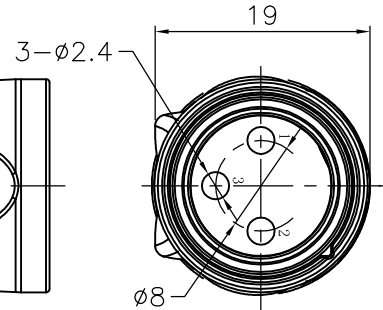
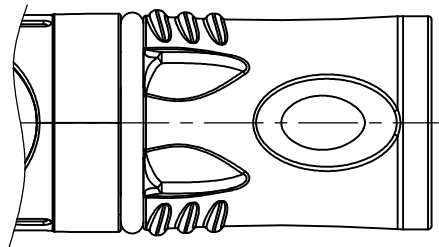

台灣日昇電子股份有限公司
ISSUE APPROVED
 發行核可

本文件與發核紙正本相符

Note(備註):
 1. trademark is carving by laser.
 (商標為雷射雕刻)

List:

ERP link (品號)	Part No. (品名)	Shell plated (外殼電鍍)	Pin plated (插針電鍍)	CAP+BOOT (螺套+尾套)
5111070319	SVP555X-WP	Matt Nickel(啞光鍍)	Silver(鍍銀)	BK+OR(黑+橙)
5111070495	SVP555X-WP-PG		Gold(鍍金)	
5111070363	SVP555X-WP-GY-SR0		Silver(鍍銀)	BK+GY(黑+灰)
5111070415	SVP555X-WP-BK	Electro-coating Black(電泳黑)	Silver(鍍銀)	BK+GY(黑+灰)
5111070400	SVP555X-WP-BK-PG			BK+WH(黑+白)
5111070536	SVP555X-WP-BW-PG			BK+YL(黑+黃)
5111070537	SVP555X-WP-BY-PG			BK+RD(黑+紅)
5111070538	SVP555X-WP-BR-PG			BK+BK(黑+黑)
5111070539	SVP555X-WP-BB-PG			BK+BU(黑+藍)
5111070540	SVP555X-WP-BU-PG			BK+BP(黑+紫)
5111070541	SVP555X-WP-BP-PG			BK+BP(黑+紫)
5111070542	SVP555X-WP-BG-PG			BK+BG(黑+綠)

9	螺套+尾套(CAP+BOOT)	PA6+TPR	see List	1	
8	防水圈(WATERPROOF)	NBR	黑色(BLACK)	1	
7	O型圈(O-WASHER)	NBR	黑色(BLACK)	1	
6	夾線爪(CABLE CLAMP)	PA6	本色(NATURAL)	1	
5	O型圈(O-WASHER)	SILICON	橘色(ORANGE)	1	
4	塑粒(INSULATOR)	PA		1	
3	插針(PIN)	H59-1	see List	3	
2	U型圈(U-WASHER)	SILICON	橘色(ORANGE)	1	
1	鋅殼(DIE-CAST SHELL)	ZZnAL4-1	see List	1	
NO.	DESCRIPTION	MATERIAL	FINISH	Q'TY	DRAWING NO.

DIMENSIONS ARE IN MILLIMETERS	
UNLESS OTHERWISE SPECIFIED TOLERANCES	
ANGLES = ±5°	
UP TO 6 = ±0.2	
6-40 = ±0.4	
40-120 = ±0.6	
120-315 = ±1	
ABOVE 315 = ±1.6	
THIRD_ANGLE	
SCALE	1.5/1

APPROVED		DATE	2023-04-21
CHECKED		DATE	
DRAWN	吳碧珊	DATE	2023-04-14
FILE NO.	D:\CAD\SVP555\511070319_SVP555X-WP-BK-PG_CA001A4		
ERP LINK:	511070319		

		日昇電子股份有限公司 SUN RISE EXACT INDUSTRIAL CO.	
TITLE		WATERPROOF 3P XLR MALE CONNECTOR	
PART NO.	SVP555X-WP	REV.	A4

F
E
D
C
B
A

F
E
D
C
B
A